

New Items 2009

Intellibox II

Digital Servo

Digital Motor

Water Crane

Lifting Magnet

Power 4

Track Control Module

Working Model Decoder

IB-Com



The success story continues!

Intellibox II

The next Generation

Intellibox II, the successor to the legendary Intellibox which in one decade became the reference for all digital centers. Tailored for the model railroader who wants to run a railway and not play with a computer.



Artist Impression

Familiar functionality

- Data format DCC, Motorola, Selectrix
- Up to 128 speed steps
- Up to 9999 decoder addresses
- Multiple traction (consist)
- DirectDrive function
- Switching of turnouts, signals and routes
- Integrated Infrared receiver
- Connections for LocoNet, transformer, track, programming track, Booster, DCC booster and additional Infrared receiver

New features

- Large, high resolution Informative display with backlighting
- Detailed representation, therefore very readable
- Information in plain text or as function symbols
- All keys with backlighting
- Context sensitive key allocation
- Speed indication also in km/h
- Up to 32768 switchable functions per locomotive
- Locomotive data base with locomotive names
- Decoder programming in plain text
- Locomotive position display in conjunction with LISSY
- Routes callable by feedback contacts
- Help function
- Model time clock
- USB computer interface
- Low power technology

Great Prospects

If you are familiar with the Intellibox or the Control Unit you will feel right at home with the Intellibox II. Different from many other centers that have recently appeared on the Market, we have retained the Control concept of the past. The large display makes the operation simpler still. Many new functions are waiting for you.

From a technical point of view the Intellibox II is a completely new device. The proven ergonomics remain. For us it is natural that you can continue to use our previous devices.

The most noticeable innovation is the large, high resolution display. The display of the various parameters is done in plain text and function symbols. The representation is very detailed and also easy to read from the side.



Locomotive position indication in the Display

The additional keys on the right and left of the display are contextually assigned, for fast access to menu options and functions.

The speed display is not only in speed steps or percent, but now also in km/h. Up to 32768 special functions per locomotive are available.

A large locomotive database with the text display of locomotive names can be set individually.

New also is decoder programming in plain text, the detailed help function, a model clock and computer connection via the USB port.

Because of the new low power technology the heat development is greatly reduced and the heat sink is no longer required.

As before: Everything in one Box

With the Intellibox II you are completely equipped for digital operation.

The Intellibox II can operate on 2-and 3-Rail layouts. It supports 128 speed steps and 9999 decoder addresses, Locomotive, function, turnout and switching decoders in the Motorola and DCC format from different manufacturers at the same time.

A single device puts the following components of Digital systems at your disposal: Central processing unit, booster, Speed controller, key board, Programmer, interface, feedback mode, route control and LISSY Mode with the DirectDrive function.

The integrated Infrared receiver makes the direct use of an IRIS infrared remote control possible.

As bus system the Intellibox II uses the model railway network work LocoNet. The data communication is reliable and fast. Accessories can be connected to the layout easily and quickly.

The connection of the individual locomotive control system LISSY makes automation of the model railway possible without the need for a computer.

With the DirectDrive function a locomotive which passed a selected LISSY receiver can be taken over on a speed controller by the push of a button, without the input of locomotive address or name.

The integrated USB interface provides a fast connection to PC or MAC. Any software that supports the LocoNet protocol can be used for automated layout control.

For power supply we recommend our 70 VA transformer 20 070 which is well co-ordinated with the Intellibox II for you.

Electronics power packs offered by some manufacturers could be illegal to use with toys and are therefore not offered by us.

LokPosi

The locomotive position display with the help of LISSY shows where a certain locomotive is on the layout at any time.

If for example you call your V200 you will see with a glance at the display that it is stopped in part 3 of the Locomotive shed. If you call the BR50 you see that it is stopped on track 5 of the Shadow station.

Part No. 65 100 Intellibox II

Prospective availability from October 2009.

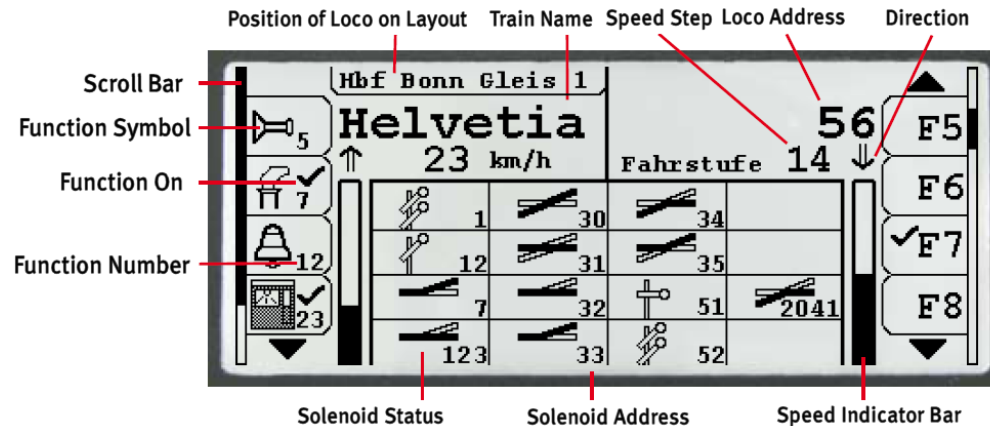

In normal operation the display is divided into three areas: Left control desk, key block, right control desk. In the left part of the illustration you see a locomotive whose data are stored in the locomotive data base. The special functions are represented by symbols. The speed indication is in km/h. In the right control desk you see the standard display for the locomotive with the address 56. The special functions are shown by number. The speed indication is in speed steps. In conjunction with the Locomotive Individual Control System LISSY the locomotive position is shown at the top of the display.

Everything in Motion – The new Drivers

Digital Servo

Mini-Servo with integrated digital decoder

The Digital Servo does not differ from the Mini Servo 81410 in form and size. Besides the servo electronics inside there is another digital decoder.

- For Märklin or DCC digital systems and analogue operation
- No additional servo decoder is required
- Switchable by locomotive functions, by turnout addresses or proportional to the speed control position
- Adjustable rotating speed
- Adjustable end stops
- Angle of rotation 180°
- Intermediate positions are possible
- Configurable with DCC CV programming or with a Motorola digital center
- With mounting material, setting levers and positioning wires 2 x 0.4 mm and 1 x 0.6 mm, each 100 mm in length
- Torque 4 Ncm
- Size 20.0 x 17.6 x 8.0 mm

The Digital servo can be installed in vehicles and also for stationary operations. The quiet and smooth jerk free operation will spoil the fastidious Model railroader.

The servo propels the element which is to be moved with the provided positioning wire. In vehicles, for example, power pickups or doors can be moved. For stationary units e.g. the drive of turnout blades, signal wings, boom barriers, water cranes, and gates is possible.

The servo can be installed in many different positions with the enclosed mounting material.



Part No. 81 310 Digital Servo

Prospective availability from June 2009.

Operating the Digital Servos

The control is possible in three modes:

- A. Using any locomotive function the Digital Servo can move to two different positions.
- B. The Digital Servo moves exactly as the regulator position indicates.
- C. Using switching keys the Servo can be controlled like a solenoid. Four different positions can be set by pressing the key.

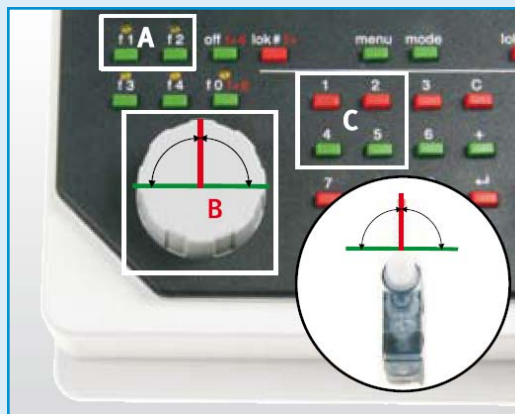

Operating the Digital Motor

The control is possible in three modes.

- A. Using any locomotive functions the Digital Motor can be moved forward or backwards.
- B. The speed controller rotating speed and rotation direction can affect the Digital Motor.
- C. Using the switching keys the Digital Motor can be controlled like a solenoid. It can move forward or backwards.

Working Models with Zip

Digital Motor

Geared motor with digital decoder

- For Märklin or DCC digital systems and analogue operation
- 3 operating modes
- Configuration by DCC CV programming or by a Motorola digital center
- With mounting material, setting levers, rope pulley and 1 m rope
- Torque 4 Ncm, size 20.0 x 17.6 x 8.0 mm



The Digital Motor has no end stops. It is suitable for all continuous rotating motion. With the enclosed pulley many kinds of rope drives can be made.

The Digital Motor is controlled by an analogue DC voltage such as a locomotive decoder (that Motor switched by special function and speed controlled by speed controller) or like a solenoid decoder (the direction of travel is selected by Keys and the speed is adjusted by CV).

Part No. 81 210 Digital Motor

Prospective availability from June 2009

Water Crane

H0 Working model with digital servo

- Finished working model of the popular water crane from Kibri with integrated Digital Servo 81 310
- For Märklin or DCC digital systems and analogue operation



With rotation of 180° two parallel tracks can be served. The central position is then the rest position.

The operation effected as described on the previous page with the digital servo. Different intermediate positions can be set.

Part No. 80 100 Water crane

Prospective availability from July 2009

Lifting Magnet

True to the Original H0 Function model

- Faithful to the original working prototype of the lifting magnet BvM L34-170 from J. Braun GmbH
- With plug for our gantry crane 80 000
- Can be applied to all models.



So far the offered lifting magnets on the model railway were pure fantasy. For the first time now a faithful to the original, functioning model is available.

	Original	Model
Diameter	1700 mm	19.5 mm
Weight	7000 Kg	6.5 g
Load capacity (Scrap)	2700 Kg	75 g
Power requirement	19.0 KW	1.1 VA

The lifting magnet power by 16 V DC or AC. The permissible on time is up to 45 seconds.

Part No. 80 020 Lifting Magnet

Prospective availability from July 2009.

BvM Round magnet for handling bulk scrap materials, like pig iron, splinters, steel and casting scrap, and also to the transport massive loads, like e.g.: Slabs, drop balls and steel mats. They are usually used on mobile excavators and Cranes of higher load carrying capacity.

The intelligent Booster Power 4

Power 4

The universal Booster for almost all Digital Systems

On model railway layouts with a lot of trains running the capacity of the center is quickly exhausted. In order to run a larger number of vehicles an additional booster which is powered by additional Transformer is used.



- Genuine multi-protocol booster for the DCC, Märklin Motorola, mfx, Selectrix and FMZ data formats
- Compatible with centers from Uhlenbrock, Märklin, Fleischmann, Piko, Lenz, ESU, Viessmann etc.
- Maximum output current 3.5 A
- Switchable to DCC brake generator mode
- With output for reversing loop module
- LocoNet capable which makes it particularly suitable for module layouts
- Short circuit and overload proof
- Connections: LocoNet B, DCC booster, Märklin booster
- Configuration by switches and LocoNet CV-programming

The LocoNet capable power 4 is higher performance multi-protocol booster. Multi-protocol means it can be installed in the 2-rail and 3-rail operations for DCC, Motorola, mfx, Selectrix and FMZ.

It makes a further 3.5 A output current available to the layout. The output of the device is protected against overload.

The Power 4 can be configured with the built-in switches. More options are however available when configuring via the LocoNet.

If the Power 4 is operated in conjunction with an Intellibox II error messages are displayed in the plain language on the Intellibox display.

In DCC systems the Power 4 can be used as a brake generator. Depending upon the preset delay and the decoders used, the locomotives brake in the section true to the prototype. As many brake sections as desired can be connected.

One or more reversing loop modules (presently under development) can be connected to the Power 4.

For power supply we recommend the 20070, our 70 VA transformer.

Part No. 63 240 Power 4

Prospective availability from August 2009.

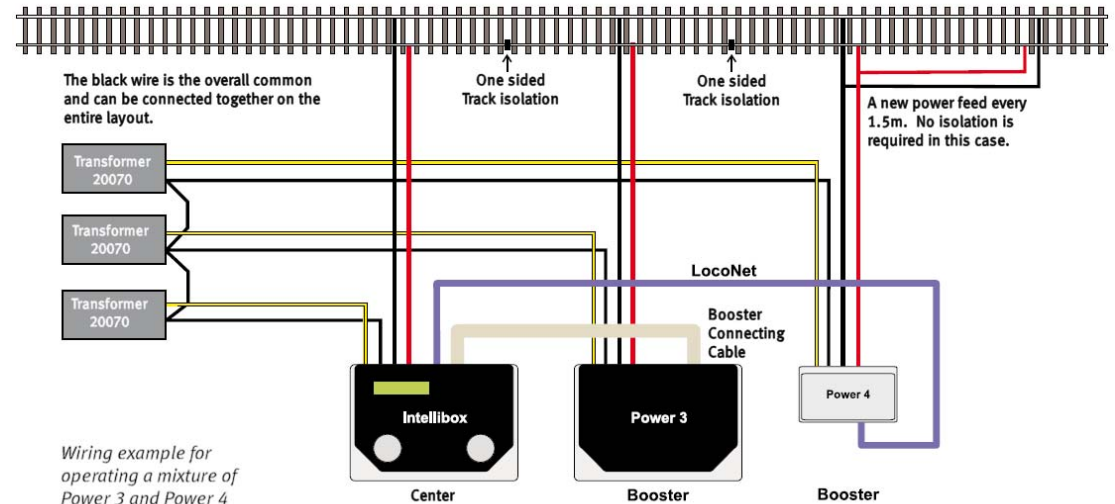

Wiring example for operating a mixture of Power 3 and Power 4

Working Models controlled simply

Track-Control 3-Key segment

In three different variations

- Segment for inserting into the track plan panel
- For switching solenoids or Locomotive special functions
- To release feedbacks

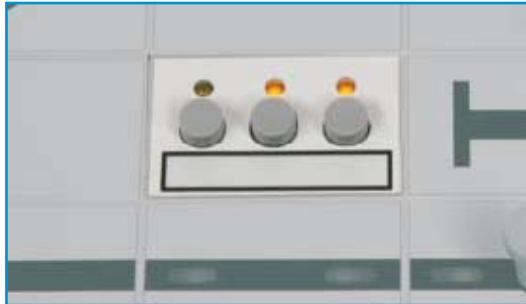

By combining 3 keys in a segment you save space and have more flexibility in the organizing of the panel.

With the low priced module all additional functions in the model railway layout, such as lighting, boom gates, gate motors, the gantry crane lifting magnet, a water crane and much more can be controlled. Routes can also to be set with these keys.

Part No. 69 260 Track-Control 3-key segment

Prospective availability from April 2009.

Track-Control Joystick

For controlling Working models

- Segment for inserting into the track plan panel
- Occupies only one field position on the desk
- Replaces several key segments



The Joystick is used to control working models, like for example our gantry crane or the water crane or working models of other manufacturers.

The Joystick can be moved in any direction so the switching functions up, down, right and left can be controlled. Special functions are switched by a slight pressure on the Joystick.

The segment produces instructions for locomotive or solenoid decoders.

Part No. 69 270 Track-Control Joystick

Prospective availability from April 2009.

Track-Control Foil

Part No. 69 095 10 Track section symbols with illumination and 15 empty fields

Prospective availability from April 2009.

Working model decoder

For Working models with 2 motors

- For Märklin or DCC digital systems and analogue operations
- 14 or 28 speed steps
- 2 motors and 4 function outputs
- Functions are switchable by function keys
- All function outputs can be time controlled, blinking and dimmable
- Configured with DCC CV programming or a Motorola digital center
- Load capacity to 1 A
- Size 52.5 x 32.5 x 11.5 mm

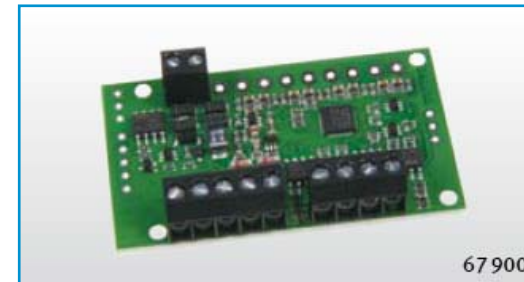

The stationary decoder is intended for installation into working models (e.g. crane models) and has two outputs for motors and four additional switching outputs. Each motor output can be switched on and off by any special function. The speed can then be controlled by the speed controller.

Working models with more than two motors can be controlled with several decoders under the same locomotive address.

Part No. 69 900 Working Model decoder

Prospective availability from March 2009.

Model Railway controlled by Computer

IB-Com

The Digital center for the PC

- The inexpensive solution to automatic layout control
- Installable with any control software which supports the LocoNet protocol
- USB computer connection
- Integrated 3.5A booster
- Connection of external devices via LocoNet
- DCC and Märklin Motorola data format



The IB-Com supports up to 9999 decoder addresses and up to 128 Speed steps. It controls up to 32 locomotives simultaneously. For each locomotive 32768 special function are switchable.

In Motorola data format up to 320 and DCC data format up to 2048 solenoids can be controlled.

It has connections for USB, LocoNet B, LocoNet T, DCC Booster, track, programming track and transformer.

The control of a model railway layout with the help of a Computer is gaining popularity. Specifically designed for this purpose is the IB-Com digital center. A compact device which contains all necessary components. Only a transformer like our 70 VA transformer 20070 is needed and feedback modules for automatic operation.

IB-Com with Win-Digipet

Alternatively the IB-Com is delivered with the program Win-Digipet Small X.

With Win-Digipet Small X up to 20 locomotives and 50 solenoids can be controlled. An upgrade to the Win-Digipet Pro X version is possible at any time.

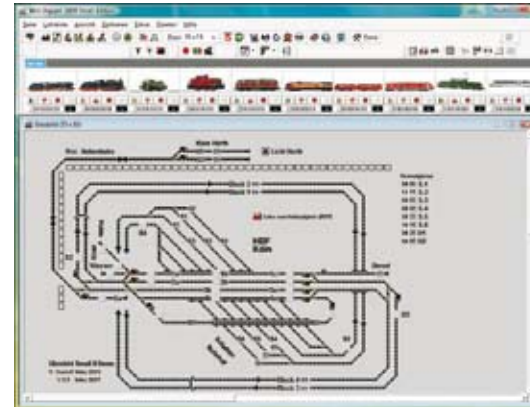

Further information about Win-Digipet can be found on the Internet under www.windigipet.de.

Part No. 65 070 IB-Com with Win-Digipet Small X, Utility software, USB cable and Manual on CD

Part No. 65 071 IB-Com, Utility software, USB cable and manual on CD

Prospective availability from May 2009.

Complete Catalog

Technology for model railways

Our 76 page catalog with all our products, many hints and references, can be obtained directly from your specialist dealer for 3.50 EUR, or from us by sending 5.00 EUR in stamps or Internet order, through our homepage.

Uhlenbrock Elektronik GmbH
 Mercatorstraße 6
 D-46244 Bottrop
 02045-85830
www.uhlenbrock.de



"Intellibox", "IntelliSound" and "Uhlenbrock Elektronik" are registered Trademarks of Uhlenbrock Elektronik GmbH.

All marks mentioned are registered Trademarks of the appropriate companies.

We reserve the right change data in this folder at any time.

Your Uhlenbrock Dealer